

ITEM NO.	PART NUMBER	DESCRIPTION	QTY.
1	420053		1
2	420055		1

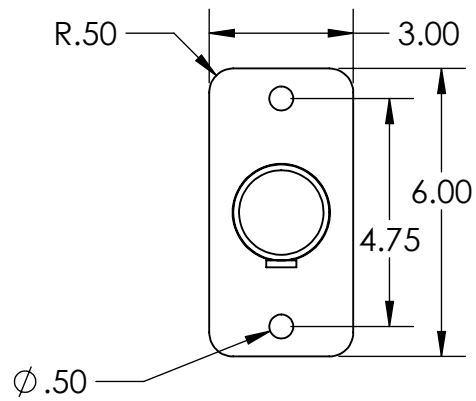
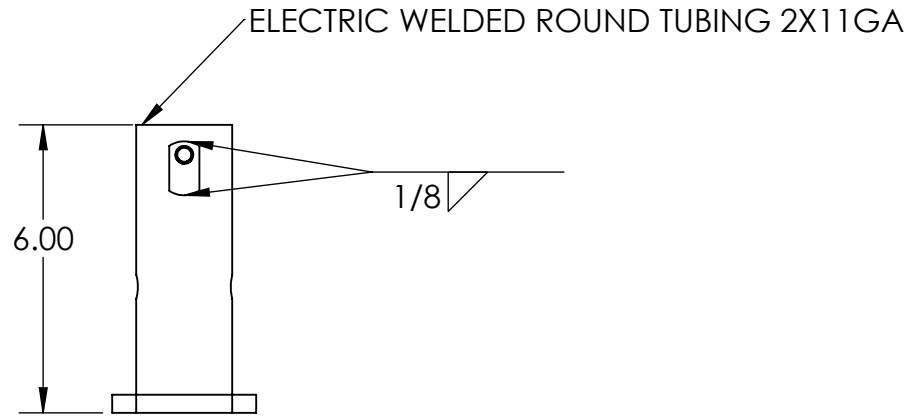
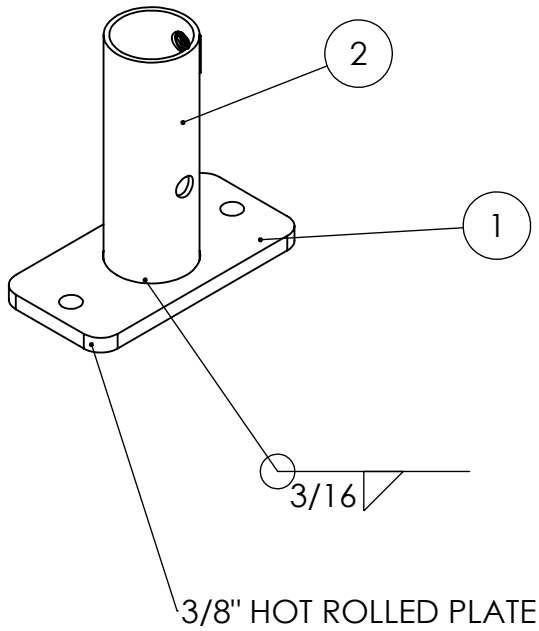

		UNLESS OTHERWISE SPECIFIED:		NAME	DATE	
		DIMENSIONS ARE IN INCHES	DRAWN			TITLE:
		TOLERANCES:	CHECKED			
		FRACTIONAL ±	ENG APPR.			
		ANGULAR: MACH ± BEND ±	MFG APPR.			
		TWO PLACE DECIMAL ±	Q.A.			
		THREE PLACE DECIMAL ±	COMMENTS:			
		INTERPRET GEOMETRIC TOLERANCING PER:				SIZE DWG. NO. REV
		MATERIAL				A 400033 A
		FINISH				SCALE: 1:4 WEIGHT: SHEET 1 OF 1
		DO NOT SCALE DRAWING				