

| ITEM NO. | PART NUMBER | DESCRIPTION | QTY. |
|----------|-------------|-----------------|------|
| 1 | 420044 | | 1 |
| 2 | 420074 | FACE MOUNT TUBE | 2 |
| | | | |

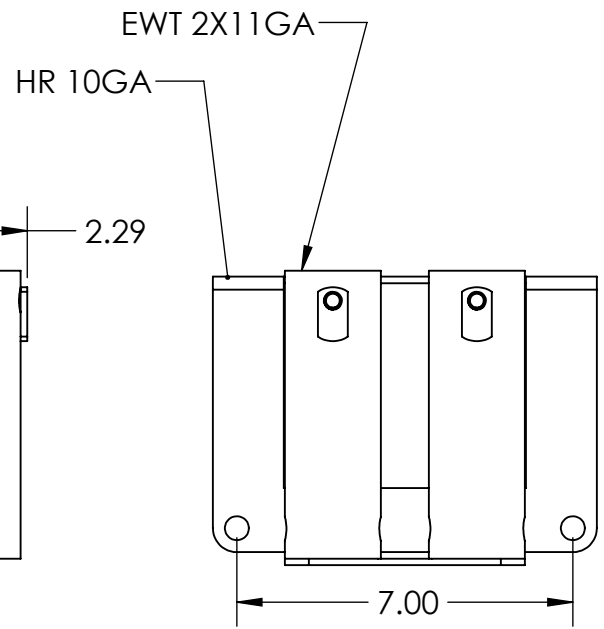
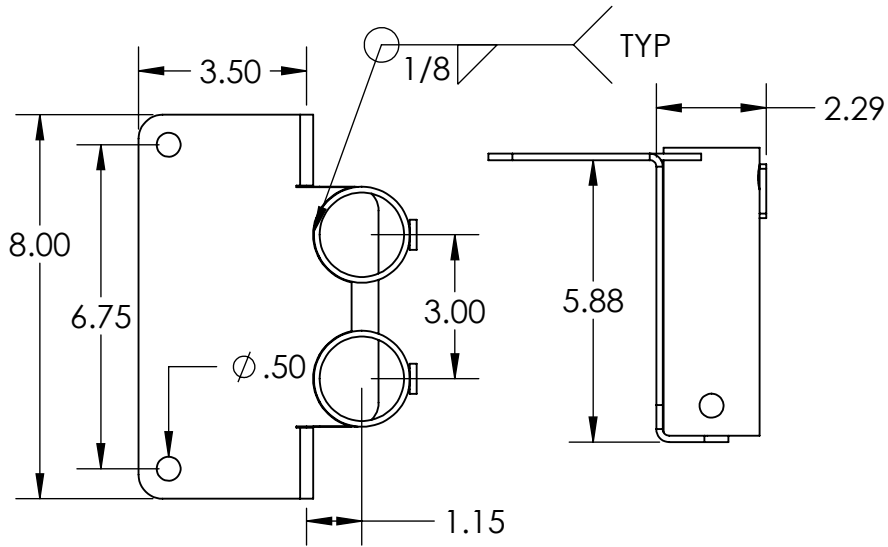
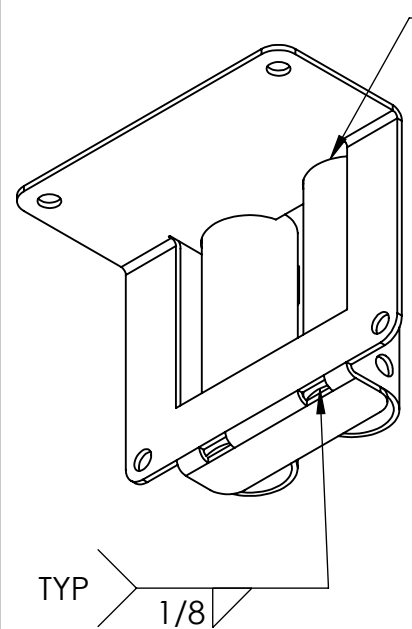
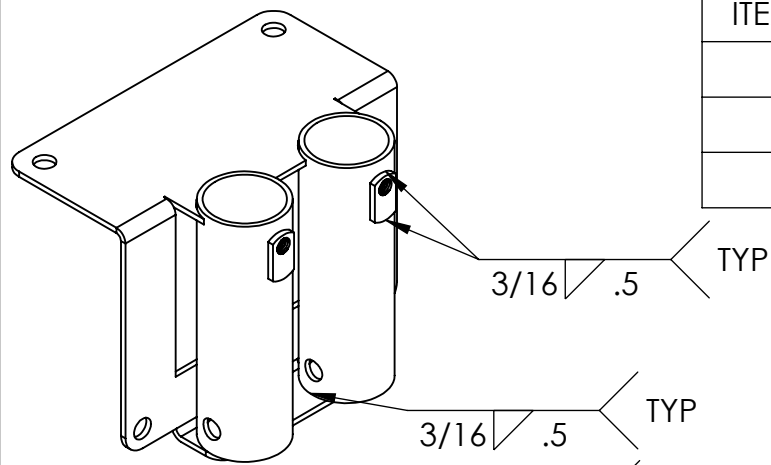

| | | | | | |
|--------------------------------------|--|-----------|--|-------------------|---------|
| UNLESS OTHERWISE SPECIFIED: | | NAME | DATE | | |
| DIMENSIONS ARE IN INCHES | | DRAWN | | TITLE: | |
| TOLERANCES: | | CHECKED | | | |
| FRACTIONAL ± | | ENG APPR. | | | |
| ANGULAR: MACH ± BEND ± | | MFG APPR. | | | |
| TWO PLACE DECIMAL ± | | Q.A. | | SIZE DWG. NO. REV | |
| THREE PLACE DECIMAL ± | | COMMENTS: | WELD PER AWS D1.3 ER70S-6 75/25 | | 400028 |
| INTERPRET GEOMETRIC TOLERANCING PER: | | | | SCALE: 1:4 | WEIGHT: |
| MATERIAL | | | | SHEET 1 OF 1 | |
| FINISH | | | | | |
| DO NOT SCALE DRAWING | | | | | |