

PROJECT REF: _____
 CONTRACTOR: _____
 APPROVED BY: _____
 SIGN HERE: _____

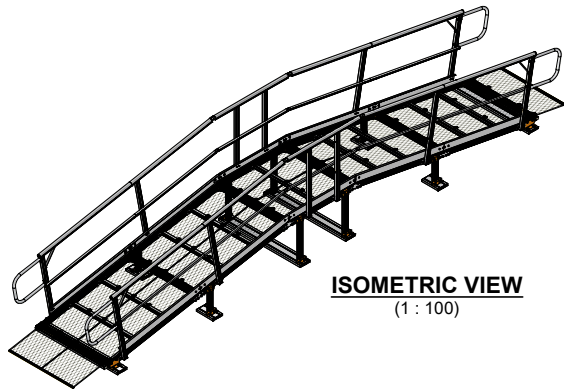

Distributed by
CAI Safety Systems

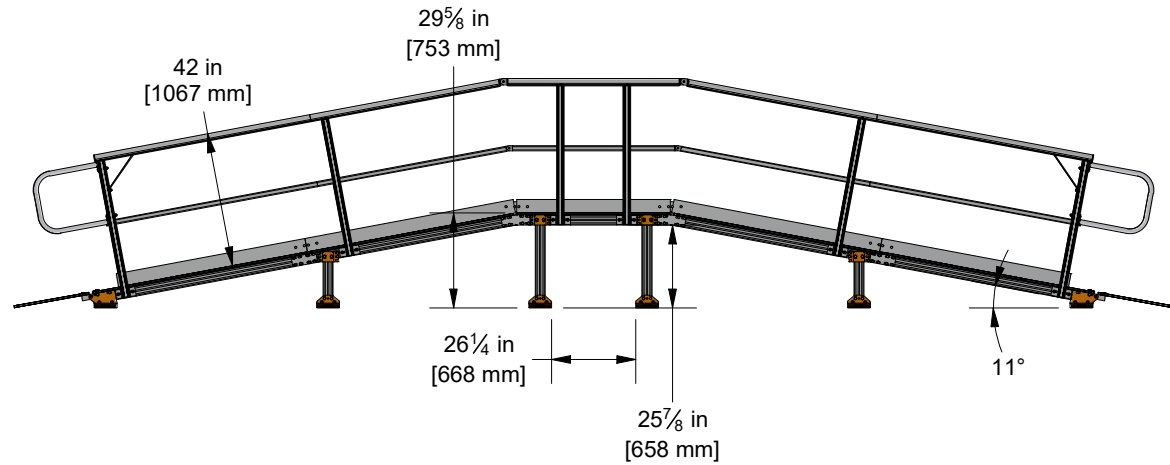
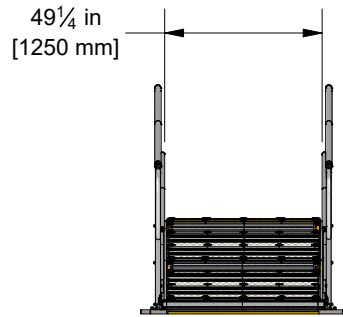
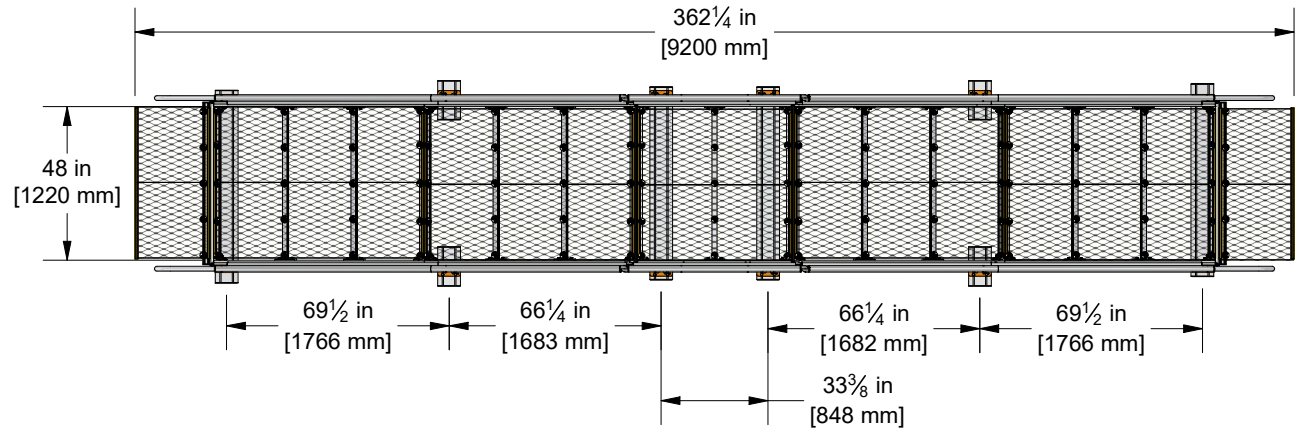

DESCRIPTION
 KOMBI Crossover Ramp with
 Guardrail - to clear 24in W x 24in
 H

PRODUCT CODE
 KBR1200.24GR

MATERIAL
 Aluminum

FINISH
 Mill Finish

1 : 60 PAGE 1 OF 1

DRN: ALD DATE: 12/4/23 SIZE: A

DWG No. KBR1200.24GR REV.

REV	DATE	BY	COMMENTS